

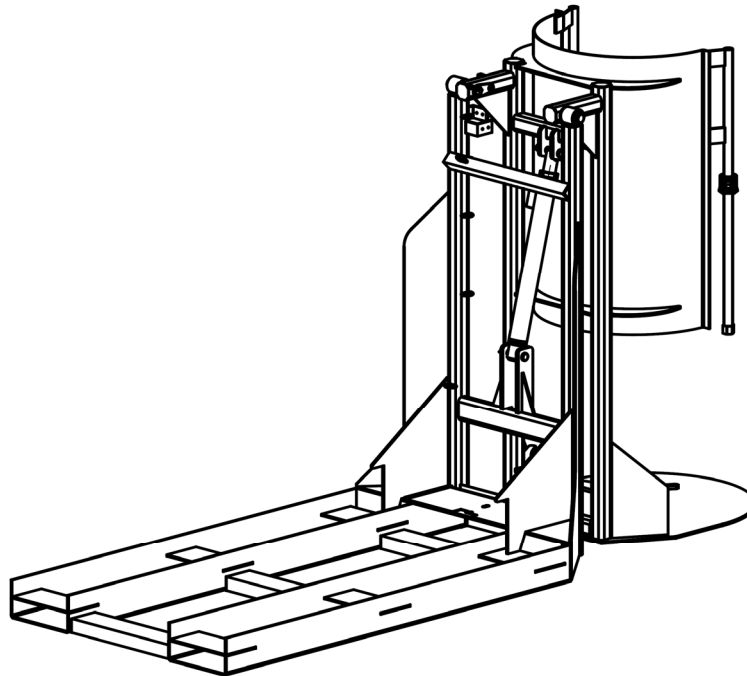

Vestil Manufacturing Corp.
 2999 North Wayne Street, P.O. Box 507, Angola, IN 46703
 Telephone: (260) 665-7586 -or- Toll Free (800) 348-0868
 Fax: (260) 665-1339
 Website: www.vestilmfg.com Email: info@vestil.com

T-HOP Electric Hydraulic Drum Dumper Instruction Manual



Receiving instructions:

After delivery, remove the packaging from the product. Inspect the product closely to determine whether it sustained damage during transport. If damage is discovered, record a complete description of it on the bill of lading. If the product is undamaged, discard the packaging.

NOTE:

The end-user is solely responsible for confirming that product design, installation, use, and maintenance comply with laws, regulations, codes, and mandatory standards applied where the product is used.

Table of Contents

Specifications.....	2
Signal Words.....	3
Hazards of Improper Use.....	3
T-HOP Exploded Parts Diagram.....	4
Electrical Circuit Diagram.....	5
DC Modular Power Unit Exploded Parts Diagram and Bill of Materials.....	6
Using the Dumper.....	7
Inspections and Maintenance.....	7- 8
Power unit operation.....	8 - 9
Hydraulic circuit diagram.....	9
Troubleshooting guide.....	10
Labeling diagram.....	11
Limited warranty.....	11

Specifications:

Dimensions and other specifications appear in the following tables:

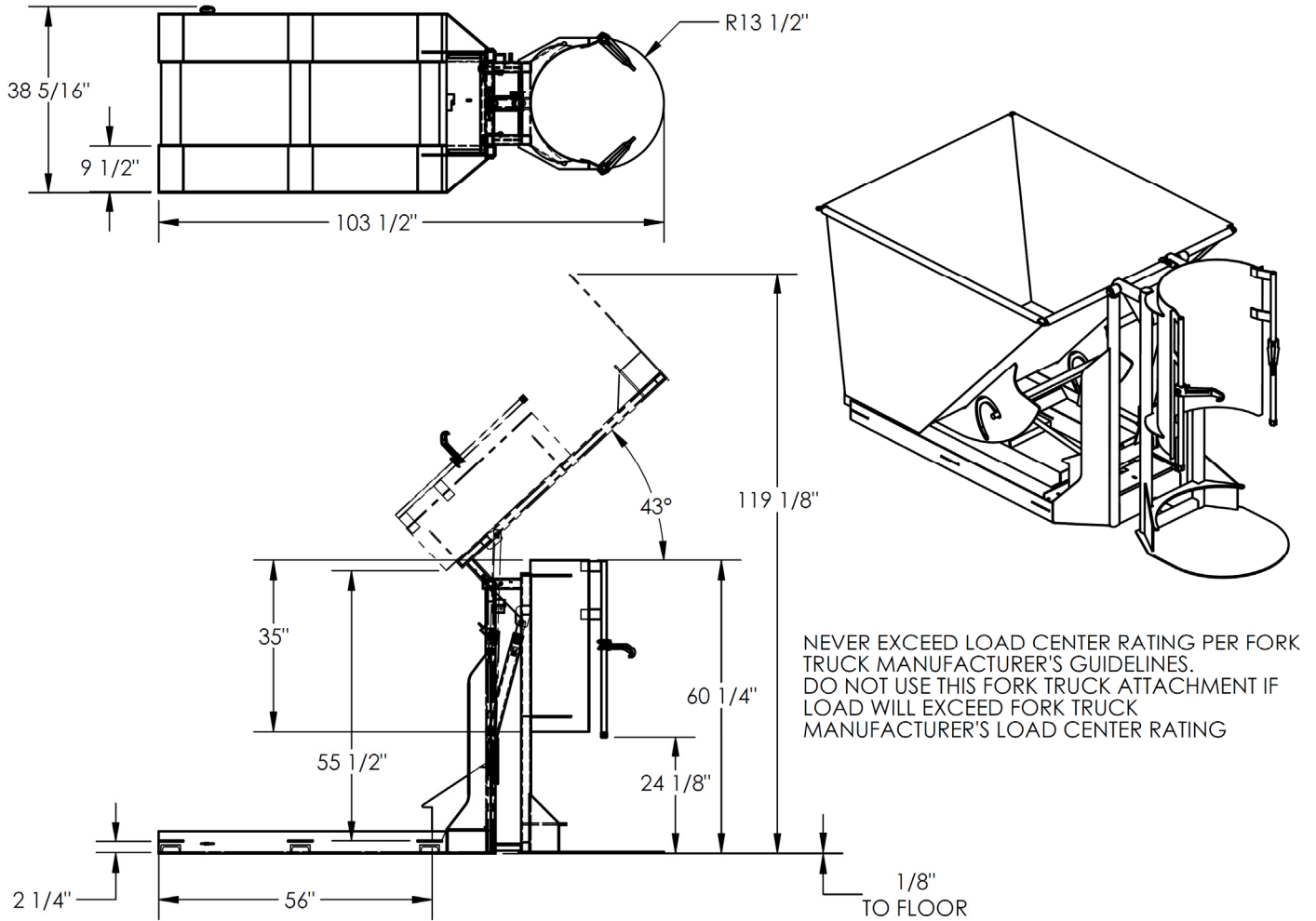

NEVER EXCEED LOAD CENTER RATING PER FORK TRUCK MANUFACTURER'S GUIDELINES. DO NOT USE THIS FORK TRUCK ATTACHMENT IF LOAD WILL EXCEED FORK TRUCK MANUFACTURER'S LOAD CENTER RATING

Dumper capacity	= 400 lb.	Overall height	= 60 ¹ / ₄ "
Dumper cradle holds	55 gallon drums	Overall rotated height	= 119 ¹ / ₈ "
Overall width	= 38 ⁵ / ₁₆ "	Dump height	= 55 ¹ / ₂ "
Overall length	= 103 ¹ / ₂ "	Dump angle	= 43°
Designed for use with 2yd ³ D-style hoppers (sold separately)			

Signal Words:

This manual uses SIGNAL WORDS to indicate the likelihood of personal injuries, as well as the probable seriousness of those injuries, if the product is misused in the ways described. Other signal words call attention to uses of the product likely to cause property damage. The signal words used in this manual appear below along with the definition of each word.



Identifies a hazardous situation which, if not avoided, WILL result in DEATH or SERIOUS INJURY. Use of this signal word is limited to the most extreme situations.



Identifies a hazardous situation which, if not avoided, COULD result in DEATH or SERIOUS INJURY.



Indicates a hazardous situation which, if not avoided, COULD result in MINOR or MODERATE injury.



Identifies practices likely to result in product/property damage, such as operation that might damage the product.

Hazards of Improper Use:

Vestil strives to identify all hazards associated with the use of this product. However, material handling is dangerous and no manual can address every conceivable risk. The most effective means for preventing injury is for the end-user to exercise good judgment whenever using this device.



DO NOT *contact* electrified wires with any part of the dumper or drum. Before using the dumper, always inspect the usage area.



- Improper or careless operation might result in serious personal injury.
- ONLY use the dumper to empty appropriately sized drums (see “Using the dumper” on p. 7).
 - DO NOT use the dumper unless it is in normal condition. Always inspect the unit before each use as described in “Inspections & Maintenance” on p. 7-8.
 - DO NOT move the dumper + hopper combination unless: 1) the fork tubes of the hopper are properly seated on top of the fork tubes of the T-HOP (see diagrams on p. 7); and 2) the safety chain of the hopper is wrapped around the fork carriage without slack (refer to [D-hopper manual](#)).
 - DO NOT stand close to or under the dumper chute while it is elevated.
 - DO NOT use the dumper UNLESS each label shown in the “Labeling diagram” on p. 11 is in place, undamaged, and readable.
 - DO NOT exceed the capacity of the dumper. The weight of the drum plus its contents must not be more than 400 pounds.
 - DO NOT modify the dumper in any way UNLESS you first obtain express, written approval from Vestil. Unapproved modifications automatically void the limited warranty (see p. 12), might make the dumper unsafe to use, and could result in serious personal injury.
 - Regular inspections and maintenance are necessary to keep the device in normal condition. Always inspect and maintain the unit as described in “Inspections & Maintenance” on p. 7-8.



DO NOT fill the hydraulic system with brake fluid or jack oils. Only fill the hydraulic system with either anti-wear hydraulic oil, viscosity grade 150 SUS at 100°F (ISO 32cSt at 40°C) or Dexron transmission fluid.

T-HOP Exploded Parts Diagram:

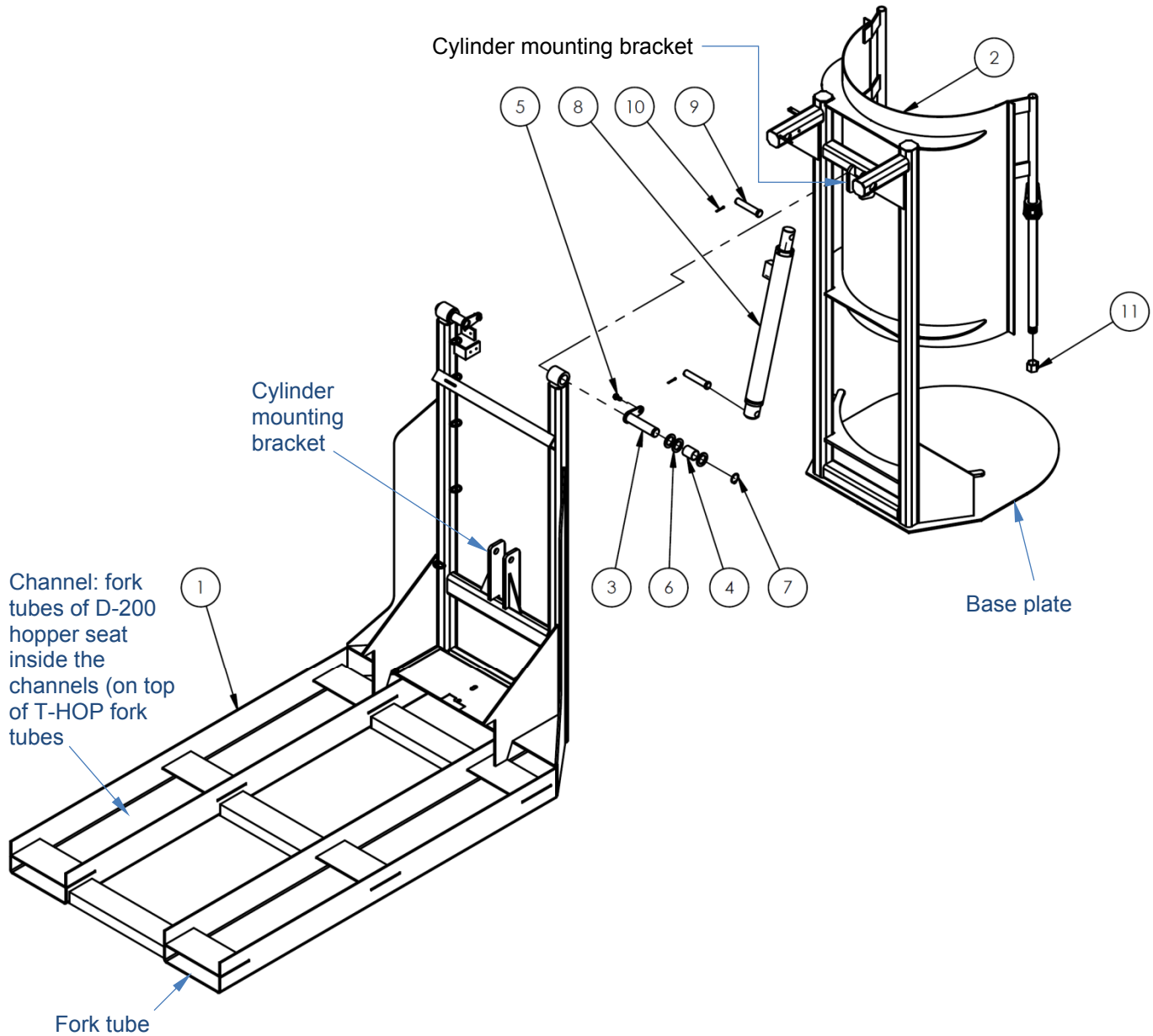

Item	Part no.	Description	Qty.
1	34-514-027	Weldment, base	1
2	34-545-011	Weldment, chute	1
3	34-612-004	Weldment, pin retainer	2
4	01-111-023	Bushing, polygon, $1\frac{1}{8}$ " inner diameter x $1\frac{9}{16}$ " long	2
5	32416	Thread cutting screw, slotted, type F, zinc plated, $\frac{5}{16}$ "-18x $\frac{3}{4}$ "	2
6	33456	Machinery bushing, plain finish, $1\frac{1}{8}$ " x 10ga.	6
7	68021	External retaining ring, phosphate finish, $1\frac{1}{8}$ "	2
8	99-021-904-001	Cylinder, hydraulic, $1\frac{1}{2}$ " x 18", ram style	1
9	33-112-034	Clevis pin, zinc plated, $\frac{3}{4}$ " x $3\frac{3}{4}$ "	2
10	65077	Cotter pin, zinc plated, $\frac{1}{8}$ " x $1\frac{1}{4}$ "	2
11	09-145-020	Pipe cap, threaded	2

Electrical Circuit Diagram, 12 VDC (34-124-006)

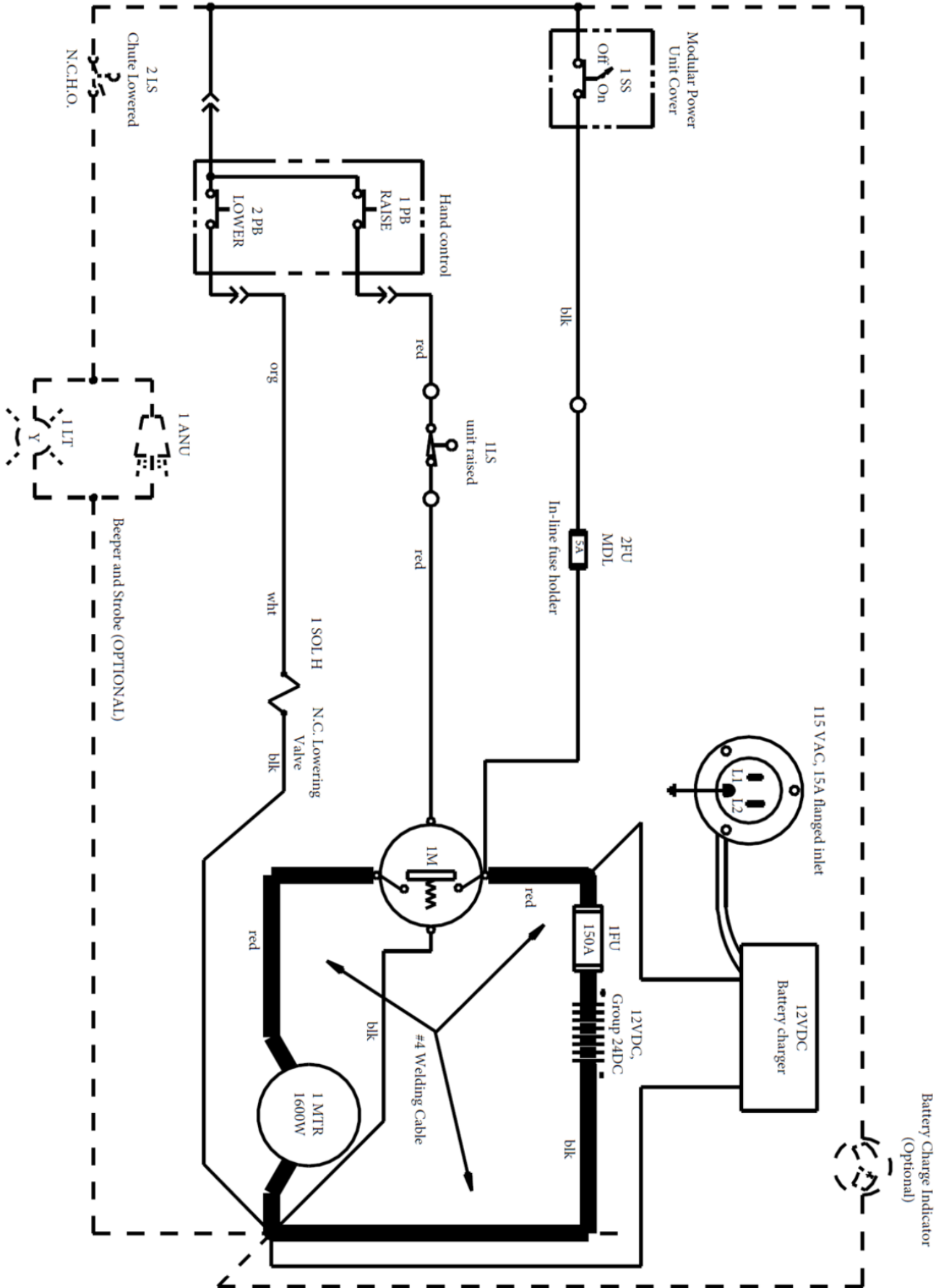

DC modular power unit exploded parts diagram and bill of materials

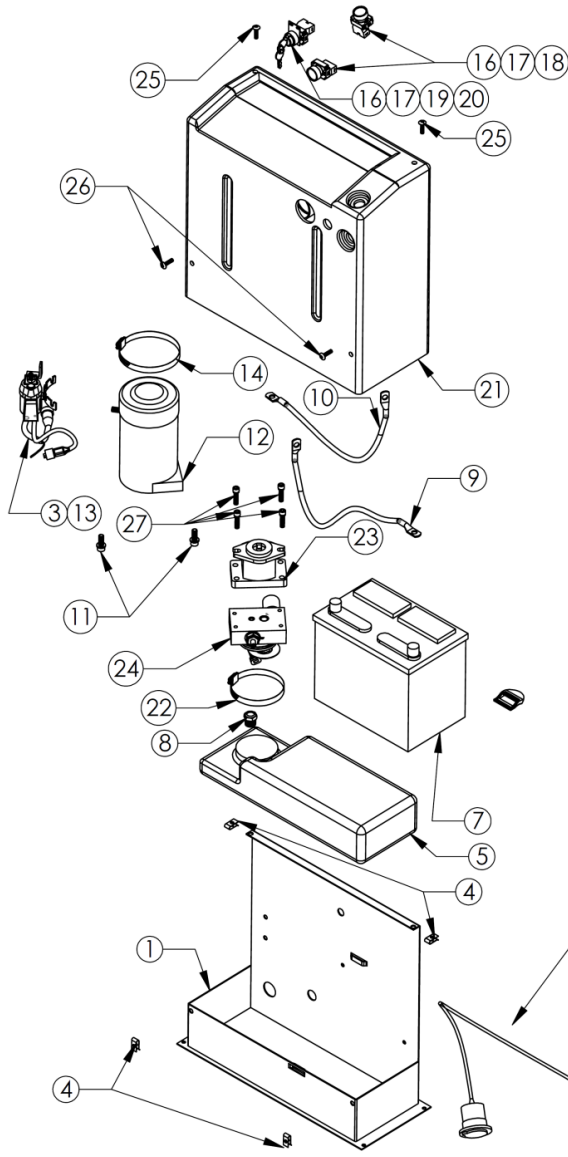

Manifold assembly (24) exploded parts diagram and bill of materials

Item no.	Part no.	Description	Quantity
31	568-015-BN70	O-ring, large	1
32	568-011-BN70	O-ring, small	1
33	99-153-058	Valve, solenoid, zero leak	1
34	99-034-010	Coil w/ weathertight plug	1
35	99-153-006	Valve, pressure relief	1
36	568-334-BN70	O-ring, 2 ⁵ / ₈ "x3"x ³ / ₁₆ "	1
37	99-031-029	Screen, inlet, 1 ³ / ₄ " diameter	1
38	99-153-038	Valve, pressure compensated flow control	1
39	01-127-010	Manifold, LHL standard	1
40	6801-06-06-NWO	Fitting, #6 JIC - #6 O-ring, 90 deg.	1
41	99-153-011	³ / ₈ "-16x1" socket head bolt	1

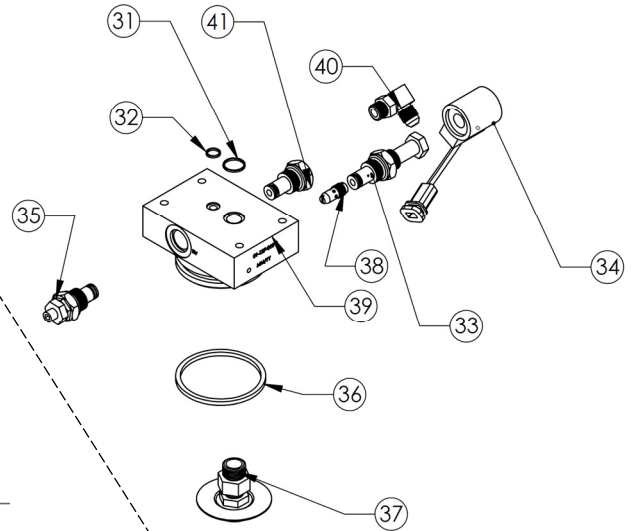

Item	Part no.	Description	Quantity	Item	Part no.	Description	Quantity
1	99-016-933	Base	1	16	Zb2bz009	Contact block base	2
2	21-034-008	Battery charger	1	17	Zb2be101	Contact block, N.O.	2
3	99-533-008	Adaptor, hand control	1	18	Zb2ba2c	Operator, black, flush, non-illuminated	2
4	37927	Tinnerman clip	4	21	99-024-010	Cover, plastic	1
5	99-023-001	Reservoir	1	22	HS52	Clamp, worm gear hose	1
6	99-034-013	Battery strap	1	23	01-143-906	Pump, hydraulic gear	1
7	99-139-003	Battery	1	*24	01-627-010	Manifold assembly	1
8	01-116-003	Breather, vent, brass fitting	1	25	29201	Screw, machine, 1 ¹ / ₄ "-20x1 ³ / ₄ "	2
9	15-533-013	23" black #4 AWG battery cable	1	26	29185	Screw, machine, 1 ¹ / ₄ "-20x1"	2
10	15-533-014	23" black #4 AWG battery cable	1	27	23255	Bolt, socket head, ⁵ / ₁₆ "-18x1"	4
11	23305	³ / ₈ "-16x1" socket head bolt	2	28	152400-03	Molded cord, charger connect	1
	33688	³ / ₈ " lock washer	2				
	33008	³ / ₈ " flat washer	2				
12	99-135-011	Motor	1	29	21-034-025	Flanged inlet w/ locking ring	1
13	15-022-004	Relay, start solenoid	1	30	3MTST3540	1" hook & loop strip	10"
14	HS64	Clamp, worm gear hose	1				
15	BG-12V	Gauge, battery, charge indicator	1				

Using the dumper:

Only use this device to dump 55 gallon drums. The net weight of the drum (drum plus its contents) must not exceed 400 pounds.

1. Place a D-200 series hopper on top of the T-HOP. Make sure that the fork tubes of the hopper seat properly on top of the fork tubes of the T-HOP (see "Exploded parts diagram" on p. 4). Then, fully insert the forks into the fork pockets **of the T-HOP**, not the hopper (see diagrams). Attach the safety chain of the hopper to the fork carriage with no slack (refer to instruction manual for hopper).
2. Load the drum onto the base plate of the chute. The drum should rest against the back of the chute.
3. Apply the drum retainers (see diagrams in "Inspections" below): to prevent the drum from sliding out of the chute, move the retainers up or down the rails as necessary and into solid contact with the rim of the drum. To move the retainers, press the rail clamps down. The hook at the end of each retainer must extend over the rim and contact the inside wall of the drum.
4. Dump the drum by pressing the white button on the pendant controller. The piston extends and raises the bottom end of the chute. The piston extends only while the white button is pressed. When the button is released, the chute stops moving. The chute maintains whatever position it is in when the button is released.

NOTE: If the net weight of the drum and its contents exceeds the capacity of the dumper, a relief valve in the hydraulic system will open. The piston cannot extend while the relief valve is open, i.e. the chute will not move.

5. Press the black (lower) button on the controller to retract the piston and return the chute to the loading position. As the piston retracts, it pulls the bottom end of the chute towards the ground. If the DOWN button is released before the chute is completely lowered, the chute will maintain its position.

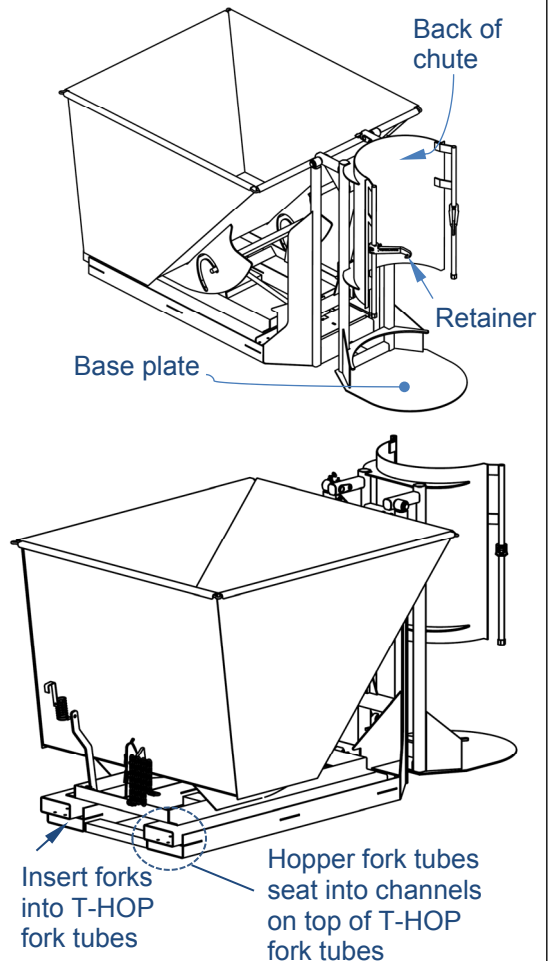

Inspections & Maintenance: Before using the dumper for the first time, create a written record describing the appearance and operation of the unit. Include detailed descriptions of pivot points, cylinder mounting brackets (where the cylinder connects to the frame), and rail clamps. Press the white button. Watch the ram and listen to the motor as the chute rotates. Record your observations about the sound of the motor and the movements of the cylinder and chute. Lower the chute and record your observations. This written record establishes "normal condition". When conducting future inspections, compare your observations to the written record to determine if a component requires repair or replacement. Do not use the dumper until it is in normal condition.

The listed components should be inspected before each use: (see also p. 4)

1. Modular power unit, pendant controller, and wiring: examine all wires for frays, cuts, tears, etc. Check battery charge status. Cycle the chute all the way up and all the way down. Recharge the battery, if necessary.
2. Hydraulic system: check the reservoir and all hoses for pinches, kinks, punctures, and leaks.
3. Rail clamps and clamp rails: examine the retainers for damage including bends, cracks, and looseness. Each clamp should maintain position (i.e. should not slide down the rail).
4. Frame: check pivot points, cylinder mounting brackets (at each end of cylinder; attachment points to the frame and the chute), base plate, vertical frame, fork tubes, and chute for cracks, damaged welds, severe wear, and corrosion.
5. Cylinder and limit switches: verify normal function. Cycle the chute through a complete dumping sequence (fully rotated and back to the ground). When the chute reaches dumping height, the power unit should stop running. The piston should extend and retract smoothly without binding or jerking. Listen for unusual sounds that might indicate binding or grinding during operation. Watch for unusual movement.

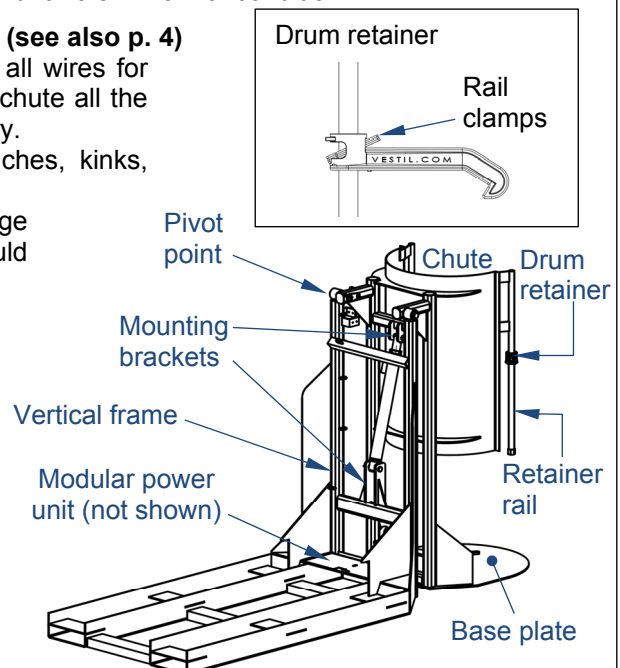

Inspect the following at least once per month:

1. **Oil level:** Remove the cover from the modular power unit. Raise the chute all the way (to the 45° “dumping position”) and observe the level of oil in the reservoir. The surface of the oil should be 1 to 1½ inches below the fill hole. If oil is needed, add oil as specified below in “Oil specifications”.
2. **Pivot points:** Check the dumper for excessive wear. Pay particular attention to pivot points between hydraulic cylinders and cylinder brackets, and between pivot shafts and hinge blocks.
3. **Floor connection points:** anchor bolts should prevent the frame from lifting off of the ground during chute operation. Concrete around each anchor bolt should be intact, i.e. not cracked or chipped.
4. **Fasteners:** check each fastener connection (nuts, bolts, pins, etc.). Tighten loose connections. Replace all damaged hardware.
5. **Hydraulic hoses and electrical wires:** check each wire and hose for damage (frays, kinks etc.).
6. **Labels:** labels should be easily readable, undamaged, and be affixed to the dumper as shown in the “Labeling diagram” on p. 11.

Oil specifications: *At least once per year* change the hydraulic oil. Change the oil as soon as it becomes gritty or looks milky (indicating that water is present). With the chute in the fully lowered position, drain the oil and replace it with either Dexron transmission fluid or anti-wear hydraulic oil viscosity grade 150 SUS at 100°F (ISO 32 cSt at 40°C).

Power unit operation:

The drum dumper is powered by an electric motor directly coupled to a gear pump. The pump pressurizes the hydraulic fluid. Fluid pressure causes the piston of the hydraulic cylinder to extend. Piston extension causes the bottom of the chute to rotate until it is elevated above the top of the chute. A hydraulic manifold bolted directly onto the gear pump houses the hydraulic control components. Each component is rated for 3,000psi working pressure.

Important components of the power unit include:

- **Electric motor:** the motor is either AC powered (wall socket) or DC powered (battery). AC-powered motors can be wired for either single-phase or three-phase operation. Regardless of phase configuration, every motor is dual-voltage capable.
- **Gear pump:** the pump shaft is directly coupled to the shaft of the electric motor. Several displacements are available to match the horsepower of the motor selected.
- **Check valve:** prevents backflow of fluid through the pump and to the reservoir. Because fluid can only flow in response to an electrical signal from the pendant controller, the chute can maintain any position between the raised and lowered configurations.
- **Pressure relief valve:** opens a path for fluid to flow back to the reservoir if fluid pressure exceeds 3,000psi.
- **Lowering solenoid valve:** electrically-operated cartridge valve with an integral screen to keep contaminants from entering the valve.
- **Pressure compensated flow control spool:** this feature regulates the flow of hydraulic oil from the cylinder back to the reservoir. It is located beneath the lowering valve. This component allows the table to lower at a predetermined constant rate regardless of the weight of the dumper and contents. Several sizes are available.
- **Displacement style hydraulic cylinder:** each cylinder includes a bleeder valve located at top end for removing air from the hydraulic system.
- **Velocity fuse:** a safety device installed in the hose port of each cylinder. If a hose is punctured while the unit is operating, the velocity fuse closes automatically. The chute remains stationary until pressure is reapplied to the system.
- **Hydraulic fluid:** HO150 hydraulic fluid. To replenish the fluid, add anti-wear hydraulic fluid with a viscosity grade of 150 SUS at 100°F (ISO 32 @ 40°C) like AW-32 or Dexron transmission fluid.

Sequence of operation:

To raise/tilt the chute, press the white (UP) button. In response, the motor turns and rotates the gear pump. As the pump rotates, oil is drawn from the reservoir, passes through the suction filter, and enters the pump.

- The gear pump propels oil through the check valve to the lift cylinder.
- Releasing the white button during operation immediately halts chute movement. Additionally, an electrical upper travel limit switch automatically turns off the motor when the chute reaches a 45° angle to the ground (horizontal).

To lower the chute, press the black (DOWN) button.

- Lowering valve opens which bypasses the check valve and allows oil in the cylinder to flow to the reservoir (through return hoses). Oil flow to the reservoir is regulated by the pressure compensated flow control valve. By regulating the volume of oil that can flow through the spool, the speed at which the chute lowers is kept constant.
- Releasing the DOWN button during operation causes all chute movement to stop. The chute will remain in the same position until you press either button on the pendant controller.

Cleaning lowering solenoid valve: If the chute slowly loses elevation without pressing the DOWN button, lower the chute completely. Then, remove, inspect, and clean the lowering cartridge valve in the following manner:

1. Lower the chute completely and turn off electrical power to the unit. If your dumper is AC powered, unplug the electrical cord from the wall socket. If your unit is DC (battery) powered, turn the power switch to the OFF position.
2. Unload the dumper.
3. Remove the nut that fastens the solenoid coil to the valve stem; then remove the coil and unscrew the valve from the manifold.
4. Inspect the valve for blockage.
5. Inspect O-rings and back-up washers for cuts, tears, etc.
6. Submerge the valve in mineral spirits or kerosene.
7. Use a thin tool, such as a small screwdriver or a hex wrench, to push the poppet in and out several times from the bottom end of the valve. The valve should move freely, about 1/16" between the closed and open positions. If the poppet sticks, the valve stem might be bent. Replace the poppet if it doesn't free up after cleaning.
8. Remove mineral oil from the valve with compressed air.
9. Move the poppet in and out.
10. Inspect the bottom of the valve cavity in the manifold for foreign matter.
11. With the thin tool, press the middle of the flow control spool, which is located in the bottom of the cavity. It should move down and up smoothly.
12. Reinstall the valve in the manifold and tighten it to 20 lb-ft of torque.

Bleeding air from hydraulic system: If the chute lowers extremely slowly or does not lower, air in the cylinders might be the culprit. Air in the hydraulic system causes the velocity fuse to close, which traps oil in the cylinder. To overcome this problem, air must be "bled" from the system.

- Completely lower the chute and unload it;
- Locate the bleeder valve located at the top of the cylinder (it looks like a grease zerk). Hold a rag over the valve and open it about a half turn with a 1/4" or 5/16" wrench. Oil and air will sputter from the valve. Jog the motor by pressing the white (UP) button for just a second. If air continues to escape from the bleeder valve, jog the motor several more times. Wait at least 5 seconds between successive jogs.
- Close the valve once air no longer is heard or seen bubbling out of the valve. At this point, just a clear stream of oil should be seen flowing from the bleeder valve. Close the valve.
- Remove the cover from the modular power unit and check the oil level in the reservoir. If the surface of the oil is lower than 1 to 1½ in. below the fill hole, then add oil until it is between 1 and 1½ inches of the fill hole. Add only anti-wear hydraulic fluid with a viscosity grade of 150 SUS at 100°F (ISO 32 @ 40°C) like AW-32 or Dexron transmission fluid.

Hydraulic circuit diagram

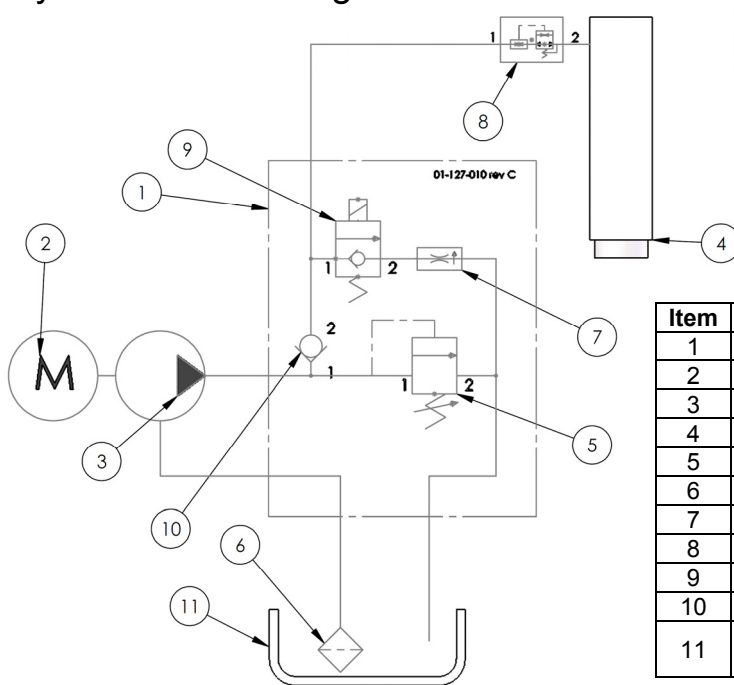

Item	Part no.	Description	Qty
1	01-127-010	Manifold, aluminum, w/o valves	1
2	01-135-052	2HP, 3-phase, 1725 RPM motor	1
3	01-143-908	Gear pump, 0.153 displacement	1
4	99-021-909	Cylinder, 2 1/2" x 18" ram style	2
5	99-153-006	Relief valve, 210 bar, size 08	1
6	99-031-029	Inlet screen, 100 mesh 2" pancake	1
7	99-153-038	Flow control, PC, 1/16" - 20, 2gpm	1
8	01-531-001	Velocity fuse, adjustable, brass	2
9	99-153-015	Valve, cartridge, NC, no coil, w/ nut	1
10	99-153-011	Check valve, size 08	1
11	99-023-002	Reservoir, L-shaped, 1.16 gal., 1.0 gal. nominal	1

Troubleshooting Guide:

Contact the factory to discuss any issues not included in the table below.

⚠WARNING DO NOT attempt to resolve any issue discussed below UNTIL the chute is fully lowered and the power supply is disconnected.

Issue:	Possible cause(s):	Solution:
1. Power unit doesn't run when white (UP) button is pressed.	1a. Transformer fuse is blown. b. No supply voltage. c. Upper-travel limit switch is engaged or bad. d. Faulty connection in control circuit. e. Bad control transformer. f. Open motor relay coil. g. (DC units) Low battery voltage.	1a. Test with meter; replace if bad. b. Test with meter. Check fuses, breakers, and overloads to determine the cause. c. Inspect and test switch. Replace if bad. d. Test all parts of circuit with meter. e. Check for 24 VAC; replace if bad. f. Test with meter; replace if bad. g. Test with meter. Charge battery if low (is motor relay LED on?)
2. Motor runs but chute doesn't move.	2a. Incorrect motor rotation.	2a. Verify motor shaft rotates counterclockwise.
3. Motor hums, chatters, or buzzes, or some type of squeal can be heard, but the chute does not move or only moves very slowly.	3a. See 2b above. b. Excess voltage drop to motor due to power wire size too small, wire run too long, or incoming voltage too low. c. (3-phase motors) Motor is "single-phasing". d. Pressure relief opening at full pressure. e. Contamination holding open the lowering valve or the check valve.	3a. Same as 2b. b. Check power installation for adequacy. Check incoming voltage <i>while motor is running</i> . Correct problem(s). c. Determine cause of loss of voltage on one phase; correct. d. Check for structural damage or binding of the rollers, etc. Check for chute overload condition. e. Remove and inspect. Clean the valve with mineral spirits.
4. Chute elevates; then drifts down.	4. See 3e above.	4. Same as 3e.
5. Chute lowers very slowly.	5a. Flow control spool is stuck. b. Pinched hose. c. Velocity fuse locking (chute only slowly creeps down).	5a. Remove plug from FC port of hydraulic manifold; push down on the center of the flow spool to ensure it moves freely. b. Check pressure, supply, and return hoses for kinks. c. Same as 7 (below).
6. Chute lowers too quickly.	6a. See 3e. b. Flow control spool is stuck.	6a. Same as 3e. b. Same as 5a.
7. Spongy or jerky chute motion.	7. Air in the hydraulic cylinders.	7. Bleed air per procedure described on p. 9 of this manual.
8. Motor and pump are quiet.	8a. Pump failure. b. Low hydraulic fluid level.	8a. Consult factory for replacement. b. Ensure reservoir is filled.

Labeling diagram:

The unit should always be labeled as shown in the diagram below. Replace any label that is missing, damaged, or not easily readable (e.g. significantly faded).

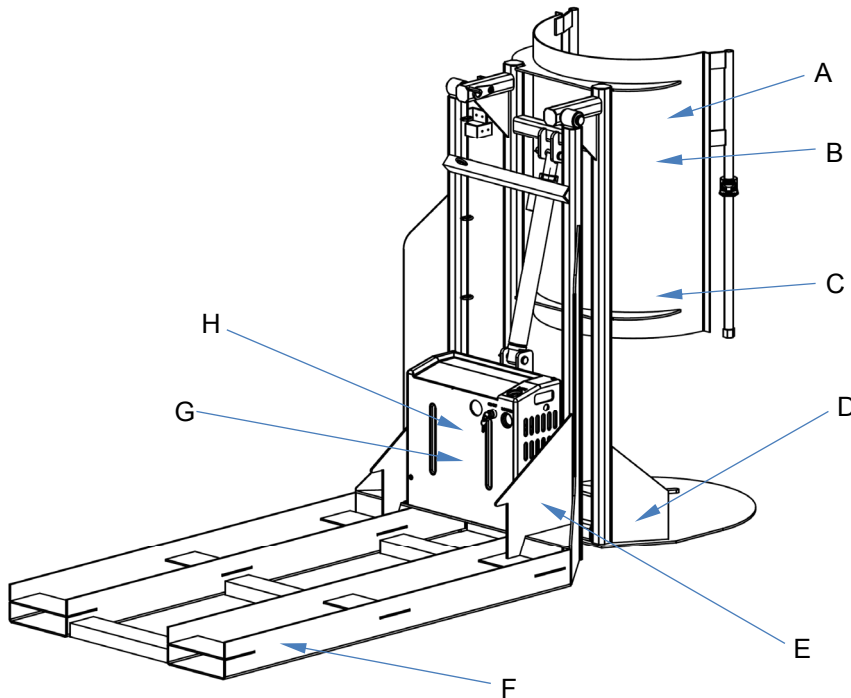

A: Label 682 (both sides of chute)

⚠ WARNING
<i>Improper operation could result in serious personal injuries or death.</i>
<ul style="list-style-type: none"> • DO NOT exceed the Maximum Rated Load. • Make sure hopper rests securely in channel on top of fork pockets. • Instruct all persons to clear the area BEFORE operating the dumper. • DO NOT operate UNLESS dumper rests firmly on the ground. • DO NOT use or move the dumper UNLESS securely attached to fork carriage with safety chain. • DO NOT move/reposition with drum dumper elevated. Return dumper to fully lowered position BEFORE moving. • DO NOT operate dumper unless BOTH rim clamps securely engage the drum. • DO NOT use dumper to transport or lift people. • DO NOT stand or walk underneath the dumper when raised. • Remove key from power unit when finished operating dumper.
<small>682</small>

B: Label 685

Maximum Rated Load: Weight of Drum + Contents must not exceed 400 lbs. (182 kgs.)
Overhead Clearance: 11 ft. (3.35m) Front End Clearance: 6 ft. (1.83m)
<small>685</small>

C: Label 220

⚠ WARNING	⚠ ADVERTENCIA	⚠ AVERTISSEMENT
KEEP CLEAR WHEN IN USE	MANTENGASE ALEJADO CUANDO SE ESTA OPERANDO	SE TENIR À DISTANCE LORS DU FONCTIONNEMENT
<small>220</small>	<small>220</small>	<small>220</small>

D: Label 287

MODEL/MODÉLO/MODÈLE _____ STATIC CAPACITY (evenly distributed) _____ lbs. LA CAPACIDAD CONSTANTE (distribuida uniformemente) _____ kgs. CAPACITÉ STATIQUE (distribuée régulièrement) _____ kgs. SERIAL/SERIE/SÉRIE _____
<small>287 REV 0812</small>

E: Label 208

⚠ WARNING	⚠ ADVERTENCIA	⚠ AVERTISSEMENT
KEEP CLEAR OF PINCH POINT	MANTENGASE ALEJADO DEL PUNTO DE CORTE	SE TENIR À DISTANCE DU POINT DE PINCEMENT
<small>208</small>	<small>208</small>	<small>208</small>

F: Label 218 (on outside of both fork tubes)

⚠ WARNING	⚠ ADVERTENCIAS
Improper use might result in death or serious personal injury. Attach device to fork carriage with safety chain/strap.	El uso impropio puede resultar en muerte o heridas personales. Atar aparato al mástil del montacargas con cadenas/correas.
<ul style="list-style-type: none"> • Drive lift truck forward until forks contact ends of fork pockets. • Chains/straps must not be able to disconnect (slide free) from carriage. • Safety chain/strap must be taut. Connect chain/strap to carriage via shortest line. 	<ul style="list-style-type: none"> • Maneje el montacargas para adelante hasta que las cuñas hagan contacto con la orilla del bolsillo de las cuñas. • La cadenas y correas no deben de deslizarse (soltarse) del mástil del montacargas. • La cadena/correa de seguridad debe de estar apretado. Asegure la cadena/correa al mástil via la ruta mas corta.
<small>218 rev 0910</small>	<small>218 rev 0910</small>

H: Label 295

⚠ WARNING
Enclosed battery contains hazardous chemicals. DO NOT handle enclosed battery UNLESS wearing eye protection and other appropriate personal protective equipment. DO NOT directly contact skin with battery. DO NOT expose to sparks or extreme heat; battery contains explosive gases.
⚠ ADVERTENCIA
La batería incluida contiene materiales peligrosos. NO use la batería incluida A NO SER que lleve protección de ojos y otros equipos de protección apropiados para el personal. NO tenga contacto directo en la piel con la batería. NO exponga a destellos o a calor excesivo, la batería contiene gases explosivos.
<small>295 rev 0111</small>

G: Label 206 (inside cover on oil tank)

ISO 32 / 150 SUS
HYDRAULIC OIL OR NON-SYNTHETIC TRANSMISSION FLUID ACEITE HIDRAULICO O LIQUIDOS DE TRANSMISION NO SINTETICOS HUILE OU LIQUIDE HYDRAULIQUE NON-SYNTHÉTIQUE
<small>206 Rev. 1003</small>
VESTIL MANUFACTURING CORPORATION • Phone (260) 665-7586 • www.vestil.com

LIMITED WARRANTY

Vestil Manufacturing Corporation ("Vestil") warrants this product to be free of defects in material and workmanship during the warranty period. Our warranty obligation is to provide a replacement for a defective original part if the part is covered by the warranty, after we receive a proper request from the warrantee (you) for warranty service.

Who may request service?

Only a warrantee may request service. *You are a warrantee if* you purchased the product from Vestil or from an authorized distributor AND Vestil has been fully paid.

What is an "original part"?

An original part is a part used to make the product as shipped to the warrantee.

What is a "proper request"?

A request for warranty service is proper if Vestil receives: 1) a photocopy of the Customer Invoice that displays the shipping date; AND 2) a written request for warranty service including your name and phone number. Send requests by any of the following methods:

Mail
Vestil Manufacturing Corporation
2999 North Wayne Street, PO Box 507
Angola, IN 46703

Fax
(260) 665-1339
Phone
(260) 665-7586

Email
sales@vestil.com

In the written request, list the parts believed to be defective and include the address where replacements should be delivered.

What is covered under the warranty?

After Vestil receives your request for warranty service, an authorized representative will contact you to determine whether your claim is covered by the warranty. Before providing warranty service, Vestil may require you to send the entire product, or just the defective part or parts, to its facility in Angola, IN. The warranty covers defects in the following *original* dynamic components: motors, hydraulic pumps, electronic controllers, switches and cylinders. It also covers defects in *original* parts that wear under normal usage conditions ("wearing parts"), such as bearings, hoses, wheels, seals, brushes, and batteries.

How long is the warranty period?

The warranty period for original dynamic components is 1 year. For wearing parts, the warranty period is 90 days. The warranty periods begin on the date when Vestil ships the product to the warrantee. If the product was purchased from an authorized distributor, the periods begin when the distributor ships the product. Vestil may, at its sole discretion, extend the warranty periods for products shipped from authorized distributors by *up to 30 days* to account for shipping time.

If a defective part is covered by the warranty, what will Vestil do to correct the problem?

Vestil will provide an appropriate replacement for any *covered* part. An authorized representative of Vestil will contact you to discuss your claim.

What is not covered by the warranty?

1. Labor;
2. Freight;
3. Occurrence of any of the following, which automatically voids the warranty:
 - Product misuse;
 - Negligent operation or repair;
 - Corrosion or use in corrosive environments;
 - Inadequate or improper maintenance;
 - Damage sustained during shipping;
 - Collisions or other incidental contacts causing damage to the product;
 - Unauthorized modifications: DO NOT modify the product IN ANY WAY without first receiving written authorization from Vestil. Modification(s) might make the product unsafe to use or might cause excessive and/or abnormal wear.

Do any other warranties apply to the product?

Vestil Manufacturing Corp. makes no other express warranties. All implied warranties are disclaimed to the extent allowed by law. Any implied warranty not disclaimed is limited in scope to the terms of this Limited Warranty.

