

# TILT MASTER STRADDLE - TMS-40-DC-PTDS

APPROX WEIGHT: 989 lbs.  
 DOES NOT INCLUDE WEIGHT OF POWER OR PACKAGING!!!

\*\*\* ANY ADDITIONS, DELETIONS, OR OMISSIONS MUST BE CORRECTED ON THIS DRAWING AS THIS DRAWING WILL BE CONSIDERED ALL INCLUSIVE \*\*\*

ALL GRAPHICS PROVIDED ARE FOR REFERENCE ONLY. IF CERTAIN DIMENSIONS ARE CRITICAL PLEASE VERIFY THOSE DIMENSIONS WITH YOUR SALESPERSON

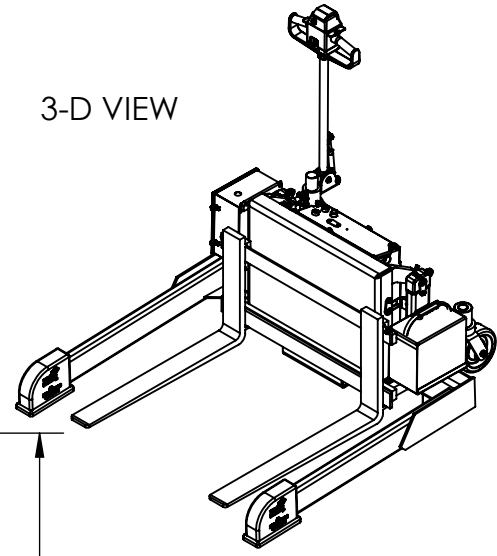
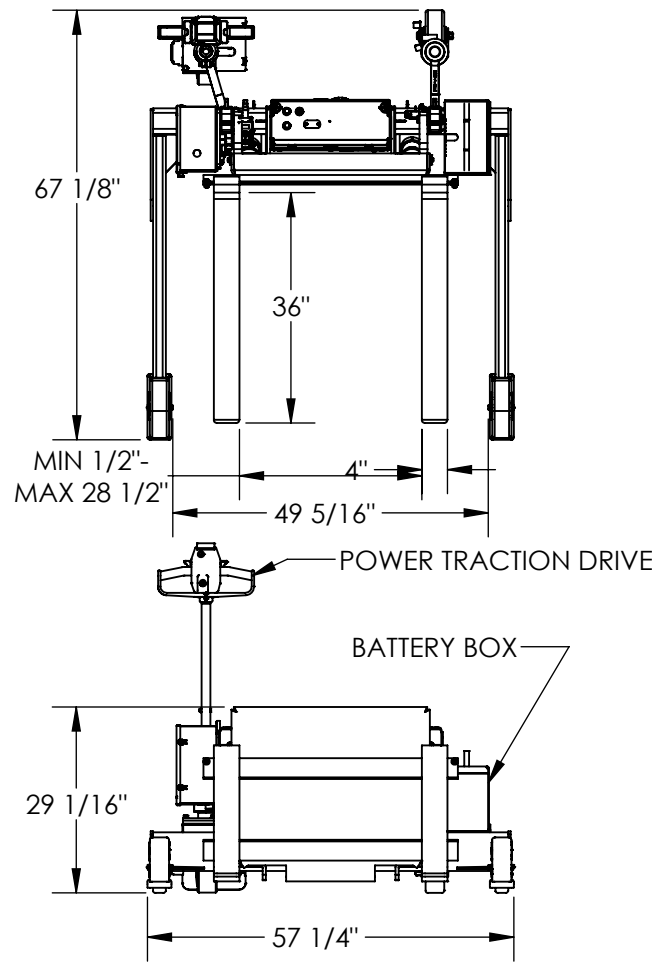

3-D VIEW

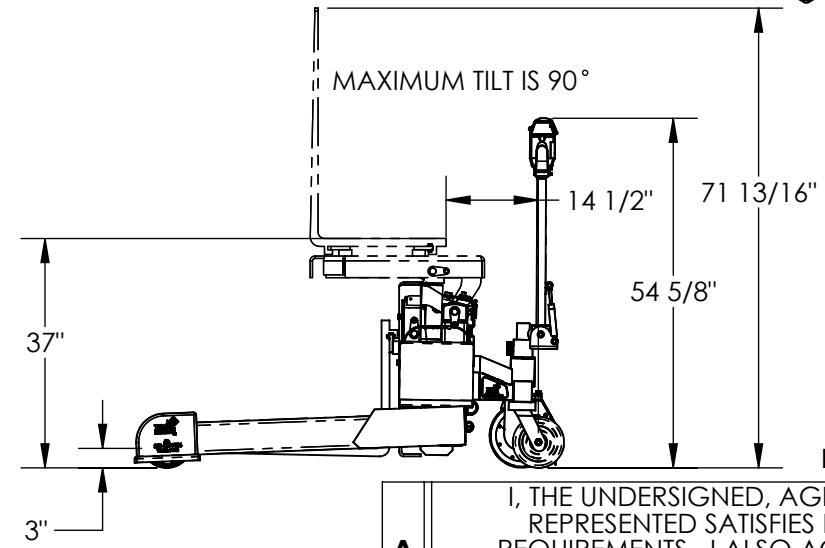

FOR INTERNAL USE ONLY  
 PROJECT SIGN OFF

SALES	
ENG.	
FAB.	
POWER	

DIMENSION TOLERANCE ± 1/4"

## STANDARD FEATURES

- MODEL NUMBER IS TMS-40-DC-PTDS
- CAPACITY IS 4,000 LBS
- FORK ADJUSTMENT IS 1/2" TO 28 1/2" I.D.
- STRADDLE I.D. IS 49 5/16"
- FORK WIDTH IS 4"
- USABLE FORK LENGTH IS 36"
- OVERALL WIDTH IS 57 1/4"
- OVERALL LENGTH IS 67 1/8"
- OVERALL HEIGHT IS 54 5/8"
- LOWERED FORK HEIGHT IS 3"
- ROTATED HEIGHT IS 71 13/16"
- LEVEL HEIGHT IS 37"
- MAXIMUM TILT IS 90°
- DC POWERED
- DURABLE LIQUID PAINT BLUE FINISH

## POWER TRACTION DRIVE

- 24V DC POWER
- VARIABLE SPEED DRIVE
- SOFT START AND STOP
- EMERGENCY BELLY SWITCH
- ELECTROMAGNETIC PARKING BRAKE/EMERGENCY BRAKE
- KEYED IGNITION
- ON BOARD BATTERY CHARGER
- BUTTERFLY STYLE THROTTLE TRIGGER
- PROGRAMMABLE DC CONTROL CARD FOR CUSTOM PREFERENCES

APPROVAL

I, THE UNDERSIGNED, AGREE THAT THE PRODUCT AS REPRESENTED SATISFIES DESIGN AND DIMENSION REQUIREMENTS. I ALSO ACKNOWLEDGE MY DUTY TO CONFIRM PRODUCT AND INSTALLATION COMPLIANCE WITH ALL APPLICABLE FEDERAL, STATE AND LOCAL REGULATIONS AND STANDARDS.

**ANY MODIFIED UNITS ARE NON-RETURNABLE**

[ ] As drawn [ ] As marked

Signed: \_\_\_\_\_ Date: \_\_\_\_\_

Printed Name: \_\_\_\_\_

LEAD TIME WILL START UPON RECEIPT OF SIGNED APPROVAL DRAWING

DISTRIBUTOR'S NAME:		P.O.#
VESTIL MANUFACTURING		X
DRAWN BY: KGH		W.O.#
DATE: 6/8/2020		X
REFERENCE: X	SCALE: 1:30	SALES: X
QUOTED LEAD TIME: X	QUOTE # X	FILE NAME:
		15-007-160