

TILT MASTER STRADDLE - TMS-20-AIR

APPROX WEIGHT: 886 lbs.
DOES NOT INCLUDE WEIGHT OF POWER OR PACKAGING!!!

*** ANY ADDITIONS, DELETIONS, OR OMISSIONS MUST BE CORRECTED ON THIS DRAWING AS THIS DRAWING WILL BE CONSIDERED ALL INCLUSIVE ***

ALL GRAPHICS PROVIDED ARE FOR REFERENCE ONLY. IF CERTAIN DIMENSIONS ARE CRITICAL PLEASE VERIFY THOSE DIMENSIONS WITH YOUR SALESPERSON

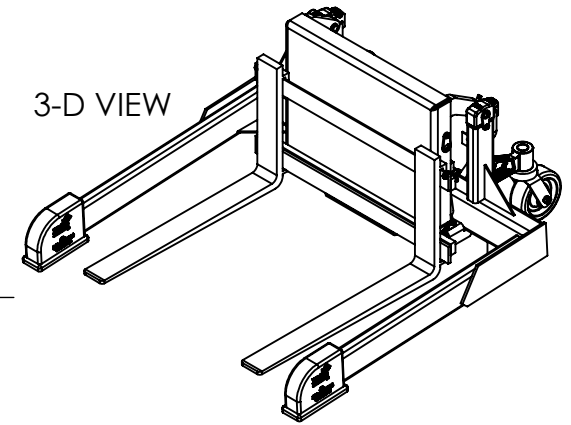
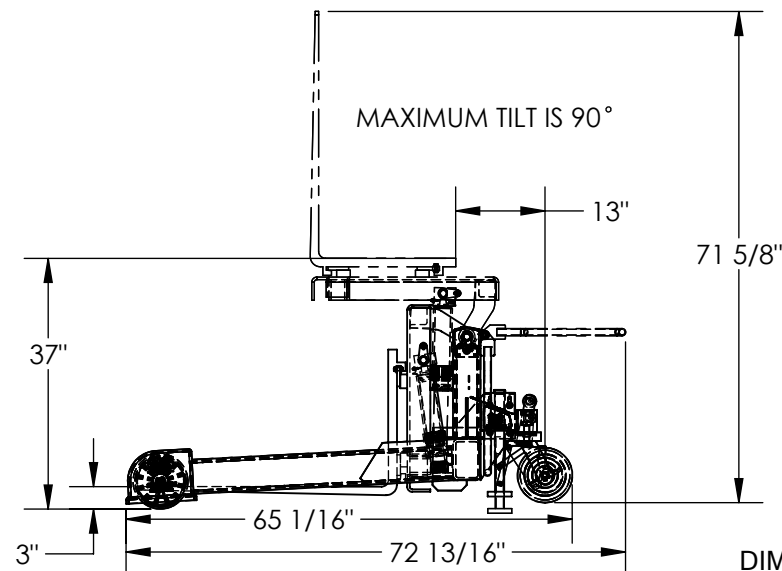
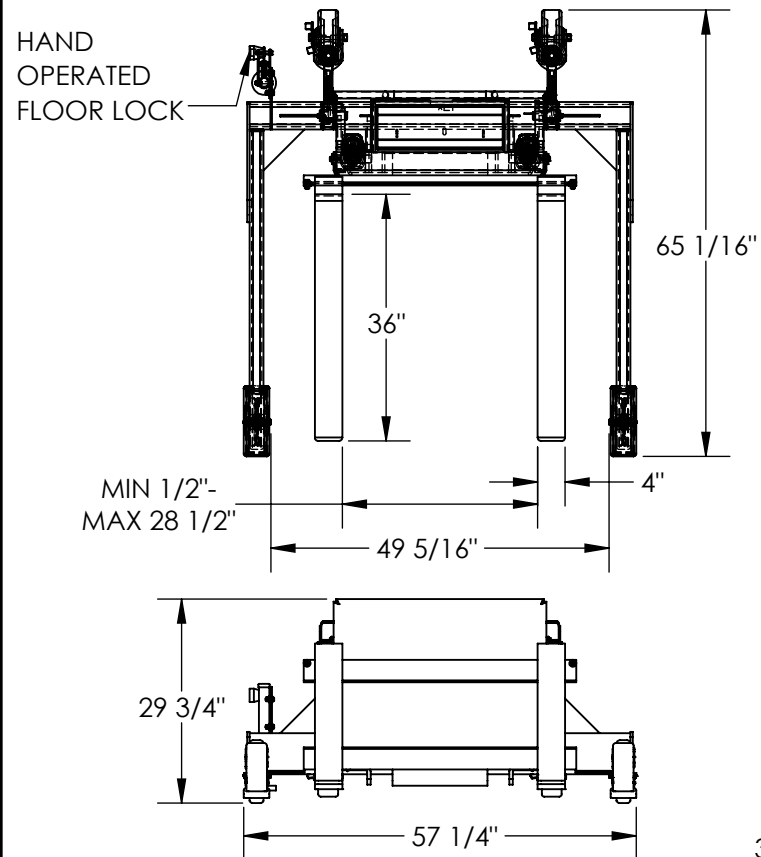

FOR INTERNAL USE ONLY PROJECT SIGN OFF	
SALES	
ENG.	
FAB.	
POWER	

DIMENSION TOLERANCE ± 1/4"

STANDARD FEATURES

- MODEL NUMBER IS TMS-20-AIR
- CAPACITY IS 2,000 lbs
- FORK ADJUSTMENT IS 1/2" TO 28 1/2" I.D.
- OPERATOR REACH IS 13"
- STRADDLE I.D. IS 49 5/16"
- FORK WIDTH IS 4"
- USABLE FORK LENGTH IS 36"
- OVERALL WIDTH IS 57 1/4"
- OVERALL LENGTH IS 72 13/16"
- OVERALL HEIGHT IS 71 5/8"
- LOWERED FORK HEIGHT IS 3"
- ROTATED HEIGHT IS 36 9/16"
- LEVEL HEIGHT IS 29 3/4"
- INCLUDES HAND OPERATED FLOOR LOCK
- AIR/OIL POWERED:
 - RECIPROCATING AIR
 - POWERED HYDRAULIC
 - 15 CFM @ 100 PSI (1/4 GPM)
- FOOT TREADLE OPERATION
- DURABLE LIQUID PAINT BLUE FINISH

SPECIAL FEATURES

NONE

I, THE UNDERSIGNED, AGREE THAT THE PRODUCT AS REPRESENTED SATISFIES DESIGN AND DIMENSION REQUIREMENTS. I ALSO ACKNOWLEDGE MY DUTY TO CONFIRM PRODUCT AND INSTALLATION COMPLIANCE WITH ALL APPLICABLE FEDERAL, STATE AND LOCAL REGULATIONS AND STANDARDS.

ANY MODIFIED UNITS ARE NON-RETURNABLE

[] As drawn [] As marked

Signed: _____ Date: _____

Printed Name: _____

LEAD TIME WILL START UPON RECEIPT OF SIGNED APPROVAL DRAWING

DISTRIBUTOR'S NAME:		P.O.#
VESTIL MANUFACTURING		X
DRAWN BY: CA		W.O.#
DATE: 12/23/2014		X
REFERENCE: X	SCALE: 1:28	SALES: X
QUOTED LEAD TIME: X	QUOTE #	FILE NAME:
	X	38-007-042