

TILT MASTER - TM-60-AIR

APPROX WEIGHT: 851 lbs.
 DOES NOT INCLUDE WEIGHT OF POWER OR PACKAGING!!!

*** ANY ADDITIONS, DELETIONS, OR OMISSIONS MUST BE CORRECTED ON THIS DRAWING AS THIS DRAWING WILL BE CONSIDERED ALL INCLUSIVE ***

ALL GRAPHICS PROVIDED ARE FOR REFERENCE ONLY. IF CERTAIN DIMENSIONS ARE CRITICAL PLEASE VERIFY THOSE DIMENSIONS WITH YOUR SALESPERSON

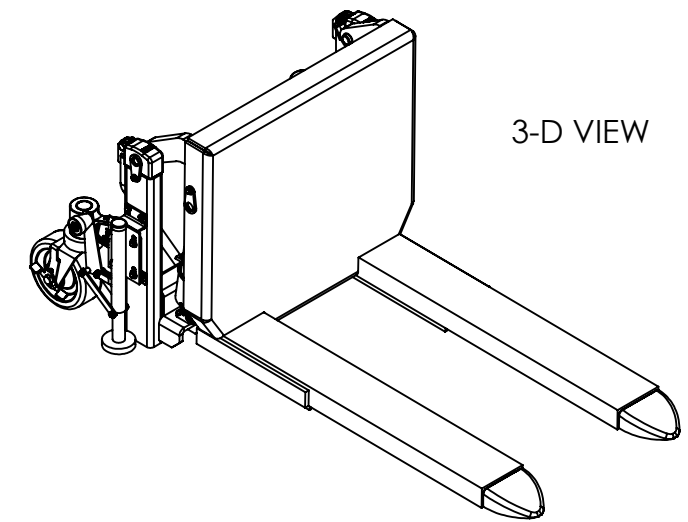
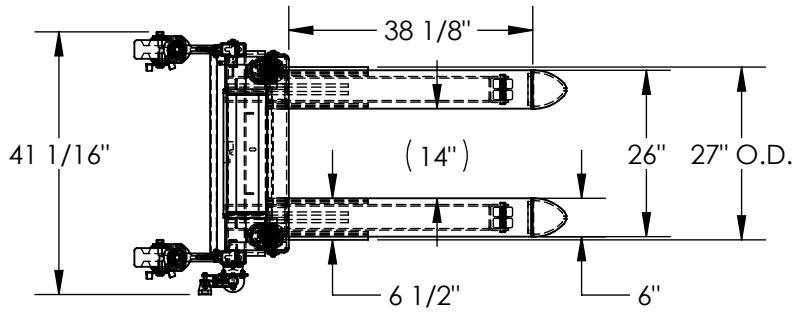

3-D VIEW

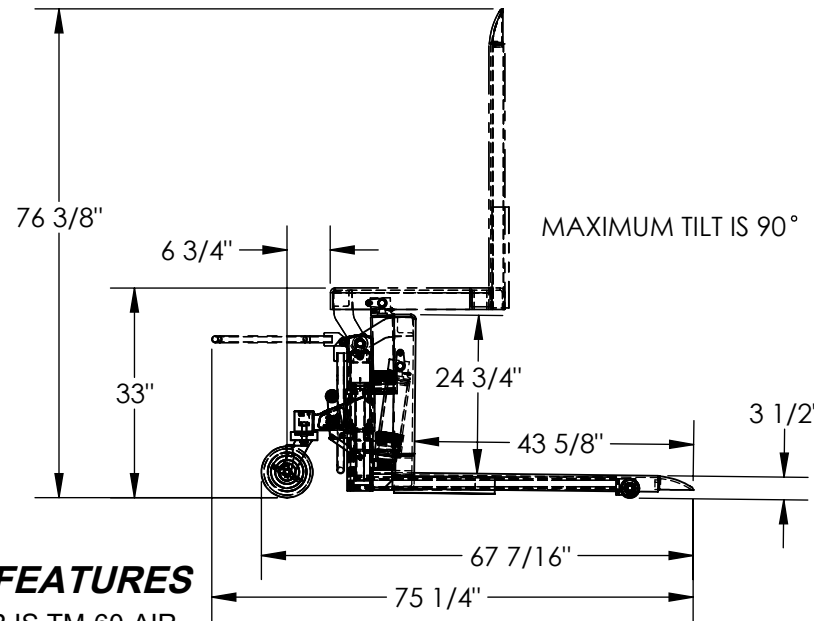

MAXIMUM TILT IS 90°

HAND OPERATED FLOOR LOCK

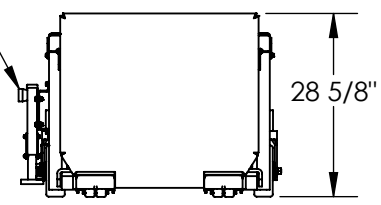

DIMENSION TOLERANCE ± 1/4"

FOR INTERNAL USE ONLY PROJECT SIGN OFF	
SALES	
ENG.	
FAB.	
POWER	

STANDARD FEATURES

- MODEL NUMBER IS TM-60-AIR
- CAPACITY IS 6,000 lbs
- OVERALL WIDTH IS 41 1/16"
- OVERALL LENGTH IS 75 1/4"
- OVERALL HEIGHT IS 76 3/8"
- ROTATED HEIGHT IS 33"
- LEVEL HEIGHT IS 28 5/8"
- FORK WIDTH IS 6 1/2" (WITH STIFFENER)
- LOWERED FORK HEIGHT IS 3 1/2"
- USABLE FORK LENGTH IS 38 1/8"
- FORK ADJUSTMENT FIXED AT 27" O.D.
- INCLUDES HAND OPERATED FLOOR LOCK
- AIR/OIL POWERED:
 - RECIPROCATING AIR
 - POWERED HYDRAULIC
 - 15 CFM @ 100 PSI (1/4 GPM)
- FOOT TREADLE OPERATION
- DURABLE LIQUID PAINT BLUE FINISH

SPECIAL FEATURES

NONE

APPROVAL

I, THE UNDERSIGNED, AGREE THAT THE PRODUCT AS REPRESENTED SATISFIES DESIGN AND DIMENSION REQUIREMENTS. I ALSO ACKNOWLEDGE MY DUTY TO CONFIRM PRODUCT AND INSTALLATION COMPLIANCE WITH ALL APPLICABLE FEDERAL, STATE AND LOCAL REGULATIONS AND STANDARDS.

ANY MODIFIED UNITS ARE NON-RETURNABLE

[] As drawn [] As marked

Signed: _____ Date: _____

Printed Name: _____

LEAD TIME WILL START UPON RECEIPT OF SIGNED APPROVAL DRAWING

DISTRIBUTOR'S NAME:		P.O.#
VESTIL MANUFACTURING		X
DRAWN BY: MTS		DATE: 6/22/2015
REFERENCE: X		SCALE: 1:30
QUOTED LEAD TIME: X		QUOTE # X
		SALES: X
		FILE NAME: 38-007-039