

# TILT MASTER - TM-20-DC

APPROX WEIGHT: 767 lbs.  
DOES NOT INCLUDE WEIGHT OF POWER OR PACKAGING!!!

\*\*\* ANY ADDITIONS, DELETIONS, OR OMISSIONS MUST BE CORRECTED ON THIS DRAWING AS THIS DRAWING WILL BE CONSIDERED ALL INCLUSIVE \*\*\*  
ALL GRAPHICS PROVIDED ARE FOR REFERENCE ONLY. IF CERTAIN DIMENSIONS ARE CRITICAL PLEASE VERIFY THOSE DIMENSIONS WITH YOUR SALESPERSON

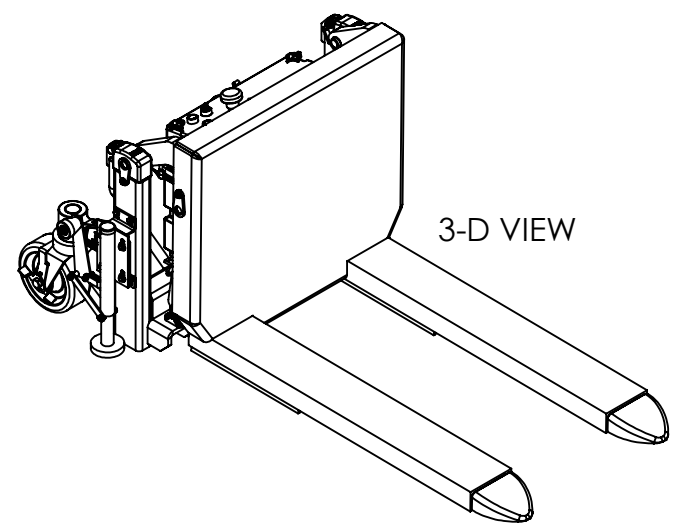
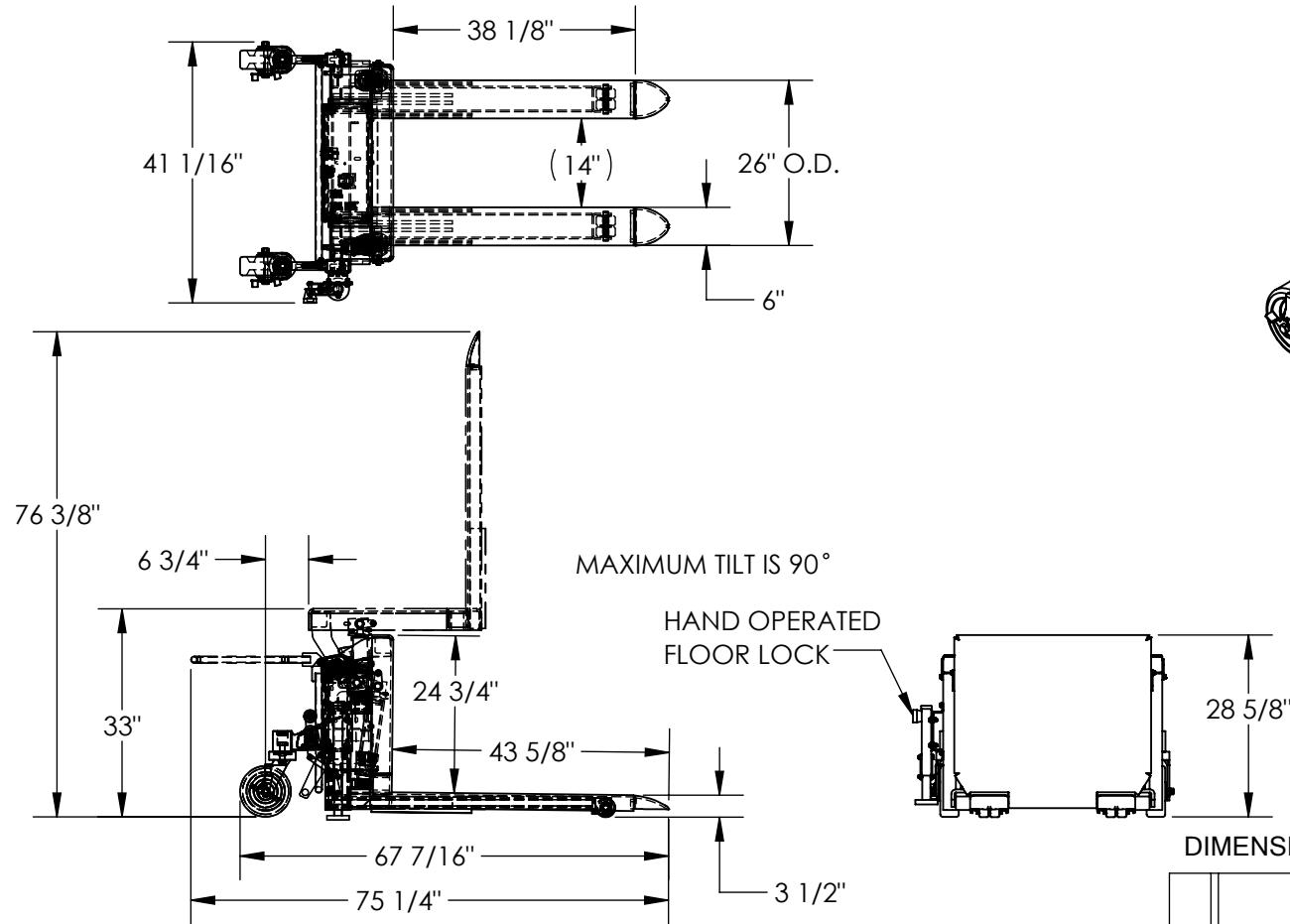

3-D VIEW

MAXIMUM TILT IS 90°

HAND OPERATED FLOOR LOCK

DIMENSION TOLERANCE ± 1/4"

FOR INTERNAL USE ONLY PROJECT SIGN OFF	
SALES	
ENG.	
FAB.	
POWER	

## STANDARD FEATURES

- MODEL NUMBER IS TM-20-DC
- CAPACITY IS 2,000 LBS
- OVERALL WIDTH IS 41 1/16"
- OVERALL LENGTH IS 33"
- OVERALL HEIGHT IS 76 3/8"
- ROTATED HEIGHT IS 33"
- LEVEL HEIGHT IS 28 5/8"
- FORK WIDTH IS 6"
- LOWERED FORK HEIGHT IS 3 1/2"
- USABLE FORK LENGTH IS 38 1/8"
- FORK ADJUSTMENT FIXED AT 26" O.D.
- INCLUDES HAND OPERATED FLOOR LOCK
- 12 VOLT DC POWERED
- ON-BOARD BATTERY CHARGER (115V AC)
- DURABLE LIQUID PAINT BLUE FINISH

## SPECIAL FEATURES

NONE

## PLEASE CIRCLE SPECIFICATIONS:

POWER	<input type="checkbox"/> AC	<input checked="" type="checkbox"/> DC (12V)	<input type="checkbox"/> AIR/OIL
MOTOR VOLTAGE	<input type="checkbox"/> 115	<input type="checkbox"/> 208	<input type="checkbox"/> 230 460
DEDICATED CIRCUIT REQUIRED 60Hz			
MOTOR PHASE	<input type="checkbox"/> SINGLE	<input type="checkbox"/> THREE	
CONTROL	<input type="checkbox"/> HAND	<input type="checkbox"/> FOOT	

**A P P R O V A L**

I, THE UNDERSIGNED, AGREE THAT THE PRODUCT AS REPRESENTED SATISFIES DESIGN AND DIMENSION REQUIREMENTS. I ALSO ACKNOWLEDGE MY DUTY TO CONFIRM PRODUCT AND INSTALLATION COMPLIANCE WITH ALL APPLICABLE FEDERAL, STATE AND LOCAL REGULATIONS AND STANDARDS.

**ANY MODIFIED UNITS ARE NON-RETURNABLE**

[ ] As drawn [ ] As marked

Signed: \_\_\_\_\_ Date: \_\_\_\_\_

Printed Name: \_\_\_\_\_

LEAD TIME WILL START UPON RECEIPT OF SIGNED APPROVAL DRAWING

DISTRIBUTOR'S NAME:		P.O.#
VESTIL MANUFACTURING		X
DRAWN BY: MTS		W.O.#
DATE: 6/18/2015		X
REFERENCE: X	SCALE: 1:30	SALES: X
QUOTED LEAD TIME: X	QUOTE #	FILE NAME:
	X	38-007-026-001