

TILT MASTER - TM-20-AIR

APPROX WEIGHT: 621 lbs.
DOES NOT INCLUDE WEIGHT OF POWER OR PACKAGING!!!

*** ANY ADDITIONS, DELETIONS, OR OMISSIONS MUST BE CORRECTED ON THIS DRAWING AS THIS DRAWING WILL BE CONSIDERED ALL INCLUSIVE ***

ALL GRAPHICS PROVIDED ARE FOR REFERENCE ONLY. IF CERTAIN DIMENSIONS ARE CRITICAL PLEASE VERIFY THOSE DIMENSIONS WITH YOUR SALESPERSON

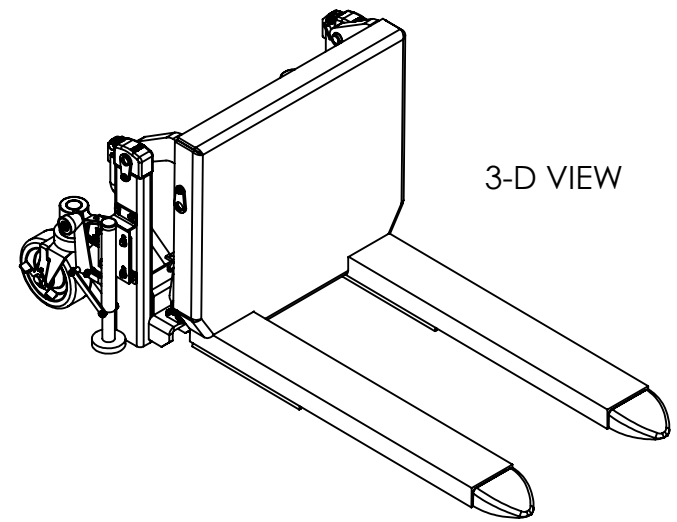
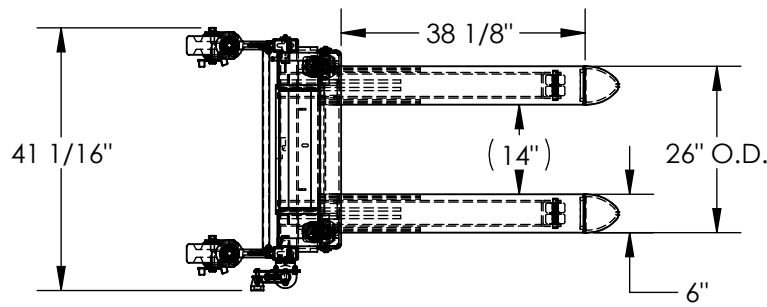

3-D VIEW

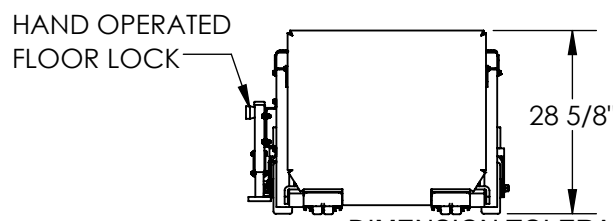
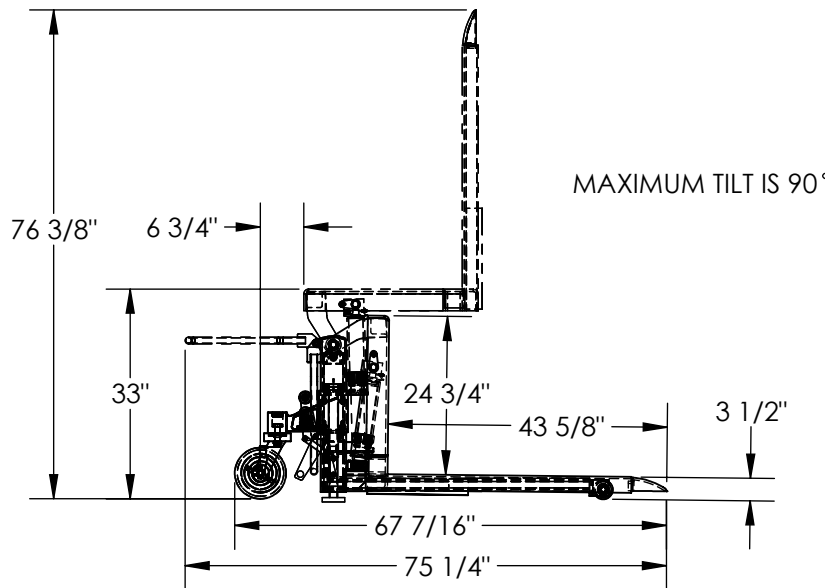

HAND OPERATED FLOOR LOCK

DIMENSION TOLERANCE ± 1/4"

FOR INTERNAL USE ONLY PROJECT SIGN OFF	
SALES	
ENG.	
FAB.	
POWER	

STANDARD FEATURES

- MODEL NUMBER IS TM-20-AIR
- CAPACITY IS 2,000 lbs
- OVERALL WIDTH IS 41 1/16"
- OVERALL LENGTH IS 75 1/4"
- OVERALL HEIGHT IS 76 3/8"
- ROTATED HEIGHT IS 33"
- LEVEL HEIGHT IS 28 5/8"
- FORK WIDTH IS 6"
- LOWERED FORK HEIGHT IS 3 1/2"
- USABLE FORK LENGTH IS 38 1/8"
- FORK ADJUSTMENT FIXED AT 26"
- INCLUDES HAND OPERATED FLOOR LOCK
- AIR/OIL POWERED:
 - RECIPROCATING AIR
 - POWERED HYDRAULIC
 - 15 CFM @ 100 PSI (1/4 GPM)
- FOOT TREADLE OPERATION
- DURABLE LIQUID PAINT BLUE FINISH

SPECIAL FEATURES

NONE

APPROVAL	I, THE UNDERSIGNED, AGREE THAT THE PRODUCT AS REPRESENTED SATISFIES DESIGN AND DIMENSION REQUIREMENTS. I ALSO ACKNOWLEDGE MY DUTY TO CONFIRM PRODUCT AND INSTALLATION COMPLIANCE WITH ALL APPLICABLE FEDERAL, STATE AND LOCAL REGULATIONS AND STANDARDS.	
	ANY MODIFIED UNITS ARE NON-RETURNABLE	
	[] As drawn [] As marked	
	Signed: _____ Date: _____	
Printed Name: _____		
LEAD TIME WILL START UPON RECEIPT OF SIGNED APPROVAL DRAWING		

DISTRIBUTOR'S NAME:		P.O.#
VESTIL MANUFACTURING		X
		W.O.#
DRAWN BY: MTS	DATE: 6/22/2015	SALES: X
REFERENCE: X	SCALE: 1:30	FILE NAME:
QUOTED LEAD TIME: X	QUOTE # X	38-007-037