

T3-AC2 Table Boxes

US Patent US D553,306 S



FSR Metal Products Group

T3-AC2



DESCRIPTION

The T3-AC2 primarily allows quick, convenient access to AC power and network access for up to two computers or laptops.

The keystone areas can be populated with a variety of connectors including network, telephone, RCA or mini stereo audio, push buttons and much more to suit unlimited applications. Alternate style snap in keystone connectors and blanks are available separately.

These stylish table boxes fit a 3½" round opening and are easily installed using a standard hole saw.

Round and square covers are available in black, brass or aluminum to blend with the decor. The small footprint provides an unobtrusive complement to any décor. The T3-AC2 can be installed in tables ¾" to 2½" thick. They are shipped with 3" installation screws and the components listed below.

The T3-AC2 includes:

- 2 AC Power outlets (pre-mounted) with 9' integral 14 GA SJT power cord
- The T3-AC2HW hardwired versions do not include a power cord. Short leads and wire nuts are provided for direct AC connection.
- 2 RJ-45 pass through connector (pre-mounted)

APPLICATIONS

- Desks
- Lecterns
- Lab Tables
- Boardroom Tables
- Control Consoles
- Classrooms

FEATURES

- Round or Square Covers
- Can be matched to nearly any décor with Black, Aluminum or Brass Top
- Easy and flexible installation
3½" Hole ¾" to 2½" table thickness
- Can be easily configured to match customer needs
- Built to Last CNC Milled Solid Cover
Rugged 16 gauge-galvanized steel Chassis
Cable Strain Relief Attach Point
- No Annoyance Factor
Cover Opens 96 Degrees so it Stays Open
Rubber Grommets for quiet closure

T3-AC2/T3-AC2HW

Top view shown with round cover

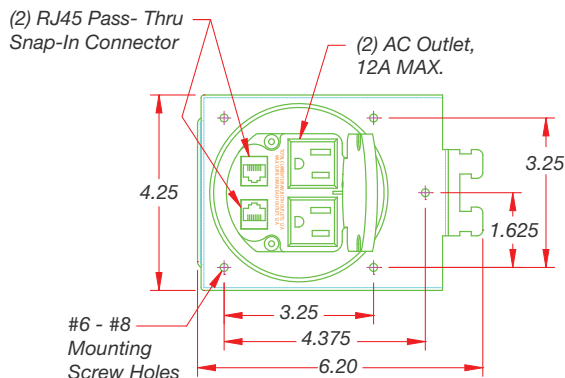

FSR Inc.

244 Bergen Boulevard, Woodland Park, NJ 07424
 Phone: 973.785.4347 · Fax: 973.785.4207
 Web: www.fsrinc.com · E-mail: sales@fsrinc.com LIT1346A

TYPICAL ASSEMBLY

T3-AC2 Assembly

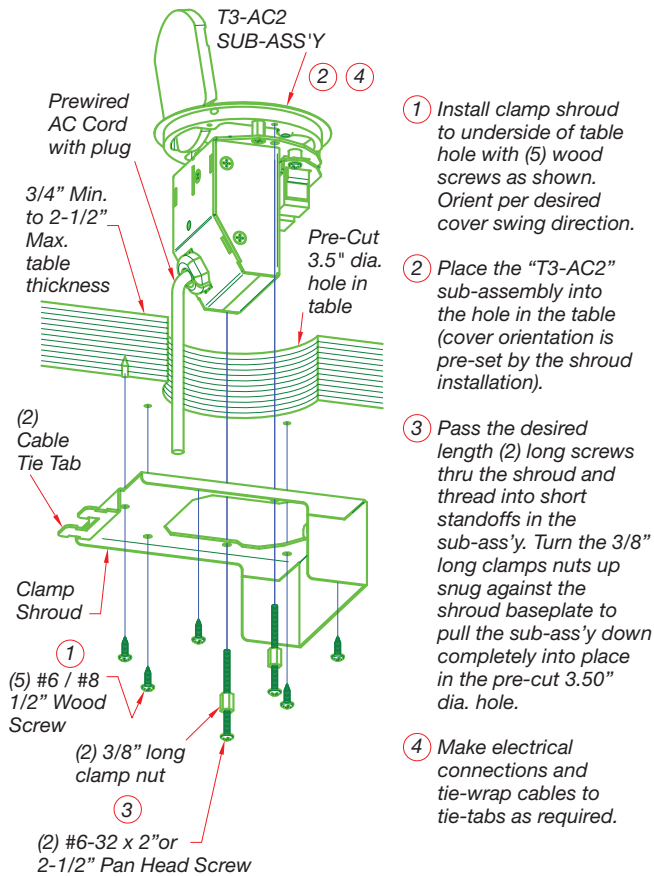

T3-AC2HW Assembly

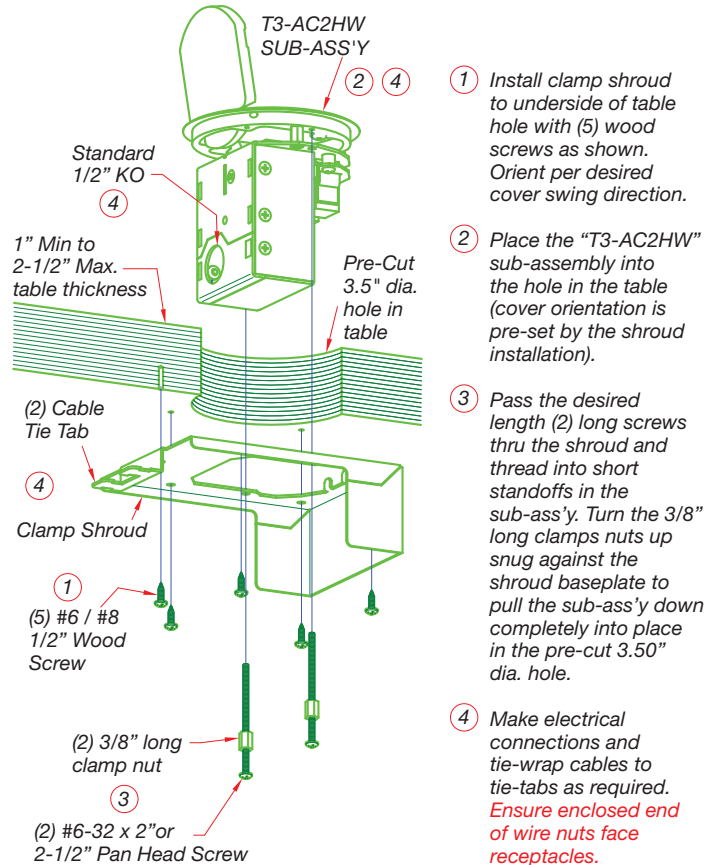

ORDERING INFORMATION

T3-AC2 3.5" Round Table Box		
16267	T3-AC2-BLK	2 A/C and 2 Keystone Connectors - Plug - Black - Round cover
16758	T3-AC2-CAT6-BLK	2 AC and 2 CAT6 Connectors - Plug - Black - Round cover
16895	T3-AC2SQ-BLK	2 A/C and 2 Keystone Connectors - Plug - Black - Square cover
17098	T3-AC2HW-BLK	2-Power, 2-Data 3.5" - Hardwired - Black - Round cover
17101	T3-AC2HW-SQBLK	2-Power, 2-Data CVR - Hardwired - Black - Square cover
16266	T3-AC2-ALU	2 A/C and 2 Keystone Connectors - Plug - Aluminum - Round cover
16894	T3-AC2SQ-ALU	2 A/C and 2 Keystone Connectors - Plug - Aluminum - Square cover
17097	T3-AC2HW-ALM	2-Power, 2-Data 3.5" - Hardwired - Aluminum - Round cover
17100	T3-AC2HW-SQALM	2-Power, 2-Data CVR - Hardwired - Aluminum - Square cover
16268	T3-AC2-BRS	2 A/C and 2 Keystone Connectors - Plug - Brass - Round cover
16896	T3-AC2-SQBRS	2 A/C and 2 Keystone Connectors - Plug - Brass - Square cover
17099	T3-AC2HW-BRS	2-Power, 2-Data 3.5" - Hardwired - Brass - Round cover
17102	T3-AC2HW-SQBRS	2-Power, 2-Data CVR - Hardwired - Brass - Square cover

Specifications
are subject
to change
without notice.



FSR

244 Bergen Boulevard, Woodland Park, NJ 07424
Phone: 973.785.4347 · Fax: 973.785.4207
Web: www.fsrinc.com · E-mail: sales@fsrinc.com