

# FORK EXTENSIONS - FE-6-66-RS

APPROX WEIGHT: 140.53 lbs.  
DOES NOT INCLUDE WEIGHT OF POWER OR PACKAGING!!!

\*\*\* ANY ADDITIONS, DELETIONS, OR OMISSIONS MUST BE CORRECTED ON THIS DRAWING AS THIS DRAWING WILL BE CONSIDERED ALL INCLUSIVE \*\*\*

ALL GRAPHICS PROVIDED ARE FOR REFERENCE ONLY. IF CERTAIN DIMENSIONS ARE CRITICAL PLEASE VERIFY THOSE DIMENSIONS WITH YOUR SALESPERSON

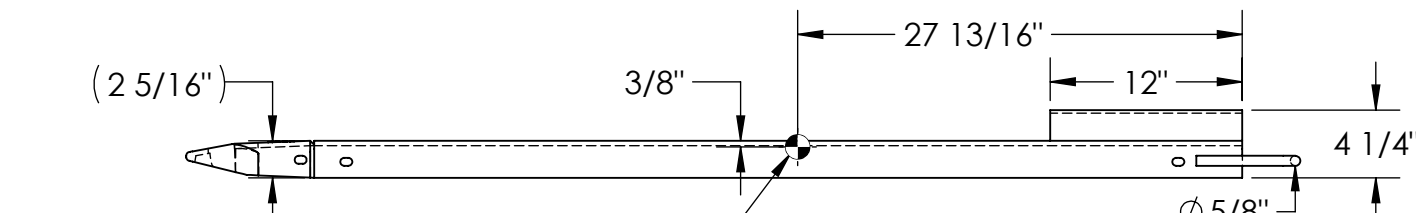
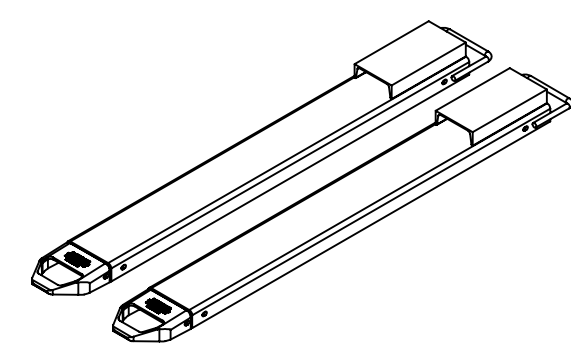
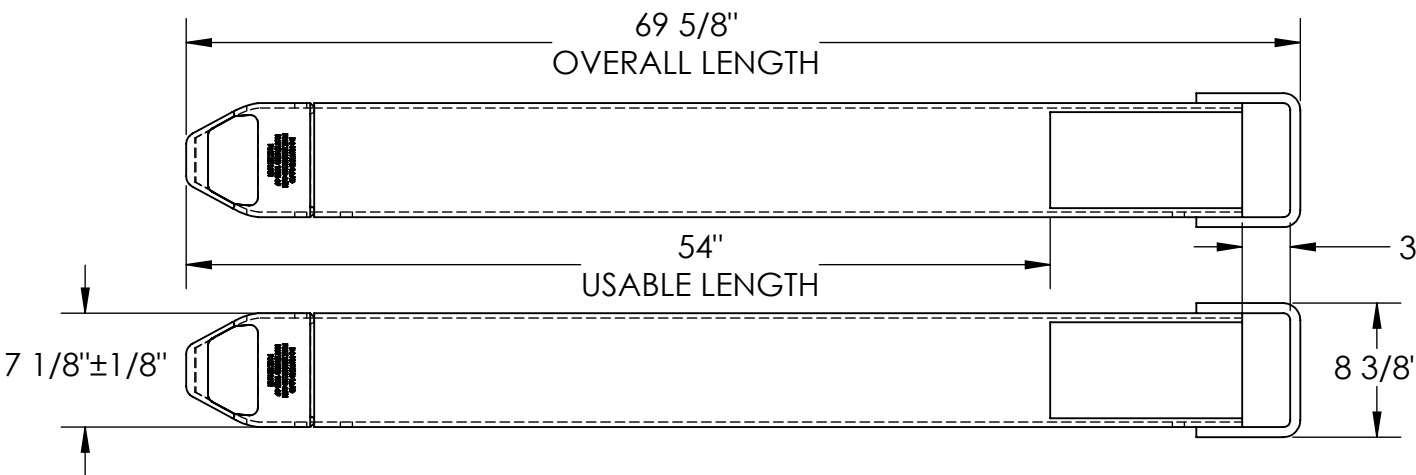

FORK EXTENSION MATERIAL THICKNESS IS 5/16"

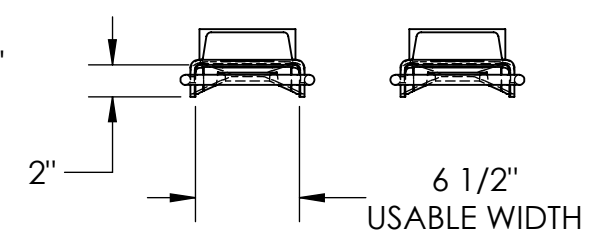

## STANDARD FEATURES

- MODEL NUMBER IS FE-66-RS
- OVERALL WIDTH IS 7 1/8" ± 1/8"
- OVERALL WIDTH W/ LOOP IS 8 3/8"
- USABLE WIDTH IS 6 1/2"
- OVERALL LENGTH IS 69 5/8"
- USABLE LENGTH IS 54"
- OVERALL HEIGHT IS 4 1/4"
- FITS 6" WIDE x 2 1/2" MAX THICKNESS FORK
- SOLID STEEL CONSTRUCTION
- TOUGH BAKED IN POWDER COATED YELLOW FINISH

## SPECIAL FEATURES

NONE

CENTER OF GRAVITY

DIMENSION TOLERANCE ± 1/4"

<b>APPROVAL</b>	I, THE UNDERSIGNED, AGREE THAT THE PRODUCT AS REPRESENTED SATISFIES DESIGN AND DIMENSION REQUIREMENTS. I ALSO ACKNOWLEDGE MY DUTY TO CONFIRM PRODUCT AND INSTALLATION COMPLIANCE WITH ALL APPLICABLE FEDERAL, STATE AND LOCAL REGULATIONS AND STANDARDS.	
	<b>ANY MODIFIED UNITS ARE NON-RETURNABLE</b>	
	[ ] As drawn      [ ] As marked	
	Signed: _____	Date: _____
Printed Name: _____		
<b>LEAD TIME WILL START UPON RECEIPT OF SIGNED APPROVAL DRAWING</b>		

APPROX. WEIGHT / LOST LOAD = 140.53 LBS PER PAIR  
MINIMUM EFFECTIVE THICKNESS = LESS THAN 1"  
CAPACITY = 4,000# PER PAIR, EVENLY DISTRIBUTED  
FORK EXTENSIONS DO NOT CHANGE THE LOAD CENTER OF EXISTING FORK TRUCK.  
NEVER EXCEED LOAD CENTER RATINGS PER FORK TRUCK MANUFACTURER'S GUIDELINES.  
DO NOT USE THESE FORK EXTENSIONS IF LOAD WILL EXCEED FORK TRUCK MANUFACTURER'S LOAD CENTER RATING.  
FORK EXTENSIONS MUST NOT EXCEED 150% ORIGINAL FORK LENGTH.

FOR INTERNAL USE ONLY PROJECT SIGN OFF	
SALES	
ENG.	
FAB.	
POWER	

DISTRIBUTOR'S NAME:		P.O.#
<b>VESTIL MANUFACTURING</b>		X
W.O.#		X
DRAWN BY: S. GINSBURG	DATE: 11/13/17	SALES: X
REFERENCE: X	SCALE: 1:12	FILE NAME:
QUOTED LEAD TIME: X	QUOTE # X	08-007-422